

DETECTION OF THE CHARACTER AND LOCATION OF THE POINTS OF INVARIANT EQUILIBRIUM BY COMPLEX THERMAL ANALYSIS

A. S. Trunin, A. S. Kosmynin, G. E. Shter and A. M. Gasanaliev

KUYBYSHEV POLYTECHNICAL INSTITUTE,
KUYBYSHEV MEDICAL INSTITUTE, KUYBYSHEV,
DAGESTAN TEACHERS' TRAINING COLLEGE, MAKHACHKALA U.S.S.R.

(Received May 6, 1987)

Utilizing complex DTA, the location of the points of invariant equilibrium of ternary and quaternary mutual systems K, Ca, Ba, Cl, MoO₄ were determined.

Judging by the papers in the literature, DTA is utilized for studying systems consisting of one and two components. Up till recently it has not been widely applied for the study of systems with a large number of components. This was due to the absence of a corresponding methodology utilizing all advantages of modern DTA apparatus. Since multicomponent systems are most widespread in nature and their study is laborious, introduction of DTA on a large scale into their investigation would substantially enlarge the sphere of its utilization. In [1], a suitable method in the form of a set of algorithms is presented, allowing to optimize wearisome studies of multicomponent systems.

One of the important procedures in studying multicomponent systems is the determination of the character and location of the points of invariant equilibrium. This paper deals with the solution of that task by means of complex thermal analysis.

It has been shown in [2] that in singular systems, in determining the composition of given ranges (simplexes) in the initial polyhedron of compositions, each range (simplex) has an eutectic star. There is no difficulty in determining the temperature of the eutectic. Differential thermal analysis in any figurative point in each simplex allows to determine the phase transition on the liquid-solid boundary corresponding to the temperature of the eutectic transition.

With non-singular systems the study becomes more complicated. For this purpose the necessary cycle of investigations has been derived [1]. The generalized concepts of differentiation and phase unit block have been introduced, allowing to

formulate the phase tree of realistic systems in the shape of a set of phase unit blocks separated from one another by secant elements. To the concept "simplex", a more generalized concept corresponds in non-singular systems, that of the phase unit block (PUB), and to the simplexizational division procedure (triangularization, tetrahedralization etc.) a more generalized procedure, that of differentiation of the initial polyhedron of composition into groups of phase unit blocks will correspond. Let us remember that a phase unit block is a concentration range of the system differing only in its characteristic entirety of phases at temperatures below the solidus.

The number of invariant points in multicomponent systems may be less or equal to the number of PUBs [3]. However, the character of each invariant point and its assignment to one or another PUB remains unknown. The essence of the problem is that individual invariant points, by reason of the particularities of the phase and chemical reactions taking place in realistic non-singular systems [4] are capable of migrating from the PUB into a neighbouring PUB, thereby changing the character of the invariant point, for instance, from eutectic into peritectic.

We suggest the following sequence of DTA procedures for multicomponent systems in order to find out the character and location of invariant equilibrium points:

(1) Temperature data of invariant points

These data are obtained by investigating, one by one, the composition of each PUB by means of DTA with simultaneous recording of electric conductivity. In this manner, complex DTA will allow to determine the phase transition temperatures corresponding to the total disappearance of the liquid phase.

(2) Determination of the assignment of the invariant points to the PUBs

For this purpose, DTA with simultaneous recording of electric conductivity is applied one by one for the compositions located on each secant element.

To temperatures of phase transition corresponding to the total disappearance of the liquid are thus determined. These are then compared with the temperatures obtained earlier in neighbouring PUBs. Two cases are possible: first, the temperatures of final crystallization of the composition in question on the secant will not coincide with either of the temperatures of invariant equilibrium points in the PUBs investigated; second, the temperature of final crystallization will coincide with the temperature of invariant equilibrium in one of the PUBs. In the first case, eutectic points with known temperatures will be present in the PUBs separated by the secant in question. In the second case, in one of the PUBs separated by the secant in question, with an invariant equilibrium temperature above the

temperature of final crystallization no eutectic point will be present, the temperature of invariant equilibrium for this PUB will correspond to a phase reaction of the peritectic type. The assignment of this invariant point to one of the PUBs is determined by the coincidence of the temperature of final crystallization on the secant and in the corresponding PUB.

These situations are illustrated by numerous examples of determining invariant points in ternary mutual systems with one compound melting congruently (Fig. 1).

Let the temperature for the invariant equilibria for each PUB be as follows: for PUB I (1-2-4) 500° ; for PUB II (2-4-5) 600° ; for PUB III (2-3-5) 650° .

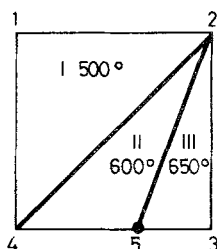

Fig. 1 Experimental determination of the temperature of final crystallization in three PUBs of a ternary mutual system with one compound. PUB-I (1-2-4), final crystallization temperature: 500° ; PUB-II (2-4-5), final crystallization temperature: 600° ; PUB-III (2-3-5), final crystallization temperature: 650°

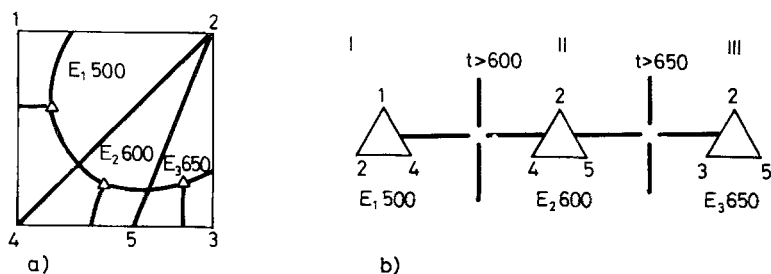

Fig. 2 Detection of the character and location of the points of invariant equilibrium for the case, when the final crystallization temperature on the secant is above the temperatures of final crystallization in adjoining PUBs. (a) Characteristic of the points of invariant equilibrium and their location in the PUBs of the system; (b) crystallization tree of the system

Analysis of the situation

(1) The experimentally obtained temperatures of final crystallization on the secants are as follows: for secant (2-4) higher than 600° ; for secant (2-5) higher than 650° . One may then conclude that all invariant points in question have an eutectic character (Fig. 2).

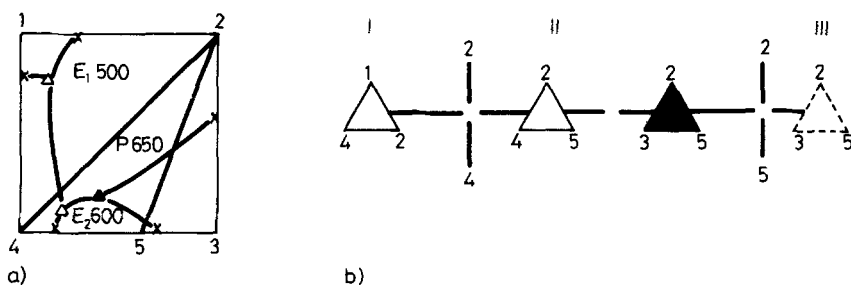

Fig. 3 Detection of the character and location of the points of invariant equilibrium for the case, when the final crystallization temperature on the secant (2-4) is above 600° , and is equal to 650° on the secant (2-5). (a) Characteristic of the points of invariant equilibrium and their location in the PUBs of the system; (b) crystallization tree of the system

(2) The temperature of final crystallization on the secant (2-4) is higher than 600° but lower than 650° ; on the secant (2-5) it is equal to 650° . In this case the location of the invariant points corresponds to the schematic representation in Fig. 3.

(3) The temperature of final crystallization on the secant (2-4) is 600° and on the secant (2-5) 650° . In this case, two mutual locations of the invariant equilibrium are possible (Figs 4 and 5). To distinguish them it is necessary to determine the temperature of the phase transition taking place directly before final crystallization on the secant (2-4). If this temperature is equal to 650° , the location of the invariant points will correspond to the schematic representation in Fig. 4. If this temperature is not equal to 650° , the case will be represented by Fig. 5.

Thus to determine the character of the points of invariant equilibrium it is necessary and sufficient to determine the temperature corresponding to the crystallization on the liquid-solid boundary of one composition in each PUB and

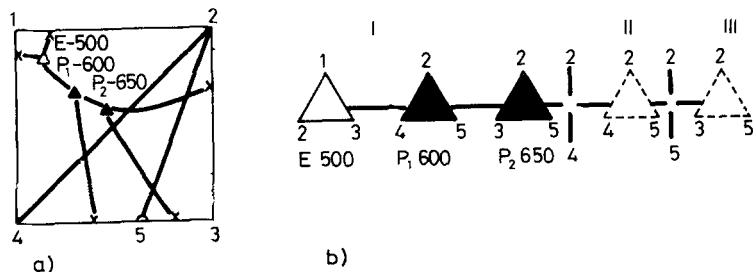

Fig. 4 Detection of the character and location of the points of invariant equilibrium for the case, when the final crystallization temperature on the secant (2-4) is equal to 600° and equal to 650° on the secant (2-5), while the phase transition temperature before the final crystallization on the secant (2-4) is equal to 600° . (a) Characteristic of the points of invariant equilibrium and their location in the PUBs of the system; (b) crystallization tree of the system

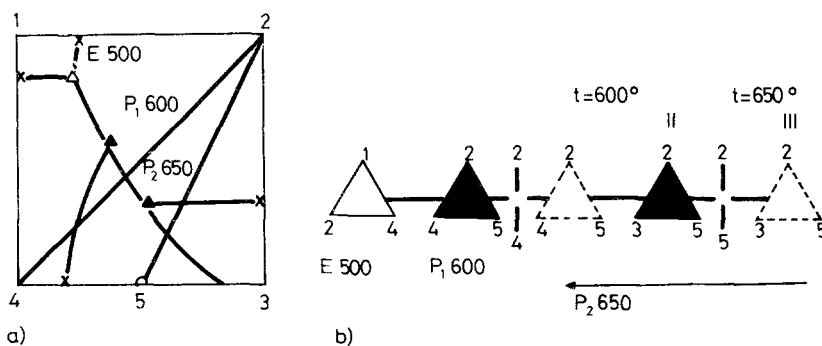

Fig. 5 Detection of the characteristic and location of the points of invariant equilibrium for the case, when the final crystallization temperature on the secant (2–4) is equal to 600° and equal to 650° on the secant (2–5), while the phase transition temperature before final crystallization on the secant (2–4) is not equal to 650°. (a) Characteristic of the points of invariant equilibrium and their location in the PUBs of the system; (b) crystallization tree of the system

one by one to the composition on each secant element. The number of such compositions investigated experimentally is equal to the sum of all PUBs and all secants of the system. An analysis of these data will allow an unequivocal determination of the character of each invariant point and its assignment to the corresponding PUB.

The above considerations have a general character, including systems with more than three components. The procedure will be illustrated by the example of constructing the crystallization tree of the quaternary mutual system K, Ca, Ba//Cl, MoO₄ from six salts with complex formation. Figure 6, in addition to the

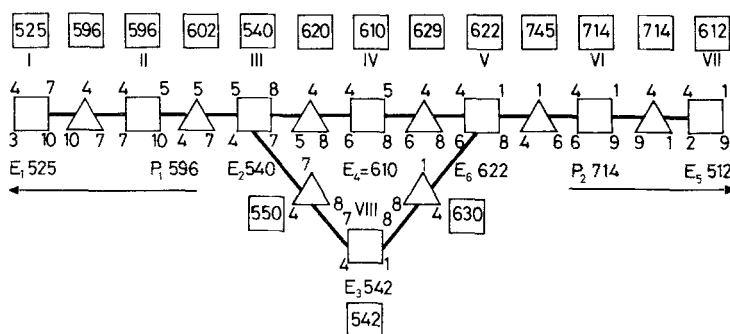

Fig. 6 Detection of the character and location of the points of invariant equilibrium and formulation of the crystallization tree of the system K, Ca, Ba//Cl, MoO₄ I to VIII—PUBs. 525°—temperature of the invariant process (experimental). 1. KCl, 2. K₂MoO₄, 3. CaCl₂, 4. CaMoO₄, 5. BaCl₂, 6. BaMoO₄, 7. D₁(KClCaCl₂), 8. D₂(2KCl·BaCl₂), 9. D₃(K₂MoO₄·BaMoO₄), 10. D₄(CaCl₂·BaCl₂)

phase tree, represents the temperatures of invariant processes, determined by complex thermal analysis, for the individual figurative points belonging to PUBs and to adjoining secant elements. The analysis of the crystallization temperature corresponding to the invariant processes, pairwise with two PUBs and the adjoining secant element allows to determine the character and location of the invariant points unequivocally.

Hence it is possible to formulate the crystallization tree of the system, indicating the temperatures and characters of the invariant points as well as their assignment to the corresponding PUBs. Thus, in addition to six eutectic points: E_1 at 525° , E_2 at 540° , E_3 at 542° , E_4 at 610° , E_5 at 612° and E_6 at 622° it could be shown that eutectic points are absent in PUB-II and PUB-VI. In fact, the temperatures of final crystallization in PUB-II and in the adjoining secant element were found to be equal to 596° , demonstrating that the invariant point migrates from PUB-II into PUB-I, changing its character from eutectic into peritectic, i.e. P_1 at 596° . Analogously, the character of the invariant point migrating from PUB-VI into PUB-VII in the form of the peritectic point P_2 at 714° was established.

The described stage of the investigation corresponds to the first information level, namely to the qualitative description of the system and is carried out after the differentiation procedure. The construction of the crystallization tree may represent the final objective of the study of multicomponent systems; or else it may precede further stages of the investigation: the formulation of phase reactions and chemical reactions in the system, and lead on to the second information level, namely to the quantitative description of the elements of the phase system in full agreement with [2].

Conclusion

Expedient utilization of complex DTA according to the proposed method allows to formulate, from a minimum number of data, the full crystallization tree of the system, indicating the temperatures and characters of the invariant equilibrium points as well as their assignment to the corresponding PUBs, this being an optimum solution of one of the most important tasks in the general algorithm of studying multicomponent systems.

References

- 1 A. S. Trunin, Principles of formulation, development and implementation of a general algorithm for investigating multicomponent systems (in Russian). Editorial board of Zh. Prikladn. Khim. Leningrad, 1984, 46 p. Manuscript deposited in VINIGI on February 26, 1984, No. 7540–80.
- 2 N. S. Kurnakov, Selected works (in Russian), Vol. 1. Izdatelstvo AN SSSR, Moscow 1960, p. 592.
- 3 A. S. Trunin, Zh. Prikl. Khim., 55 (1982) 2397.
- 4 A. S. Trunin, A. S. Kosmyrin and G. E. Shter, Zh. Prikl. Khim., 56 (1983) 964.

Zusammenfassung — Unter Zuhilfenahme einer komplexen DTA-Untersuchung wurde die Lage des nonvarianten Gleichgewichtspunktes ternären und quarternären K, Ca, Ba//Cl, MoO₄ Wechsel-systeme bestimmt.

Резюме — С использованием комплексного ДТА определены месторасположения точек nonвариантного равновесия тройных взаимных и четверной взаимной системы K, Ca, Ba//Cl, MoO₄.